



NORWEST

MANUFACTURING

71 SOUTH 215 WEST-RUPERT, ID- PHONE: (208) 436-1770 - FAX: (208) 436-1776

SECTION 200 -50 GAUGE WHEELS



ADJUSTABLE GAUGE WHEELS



ZERO PRESSURE

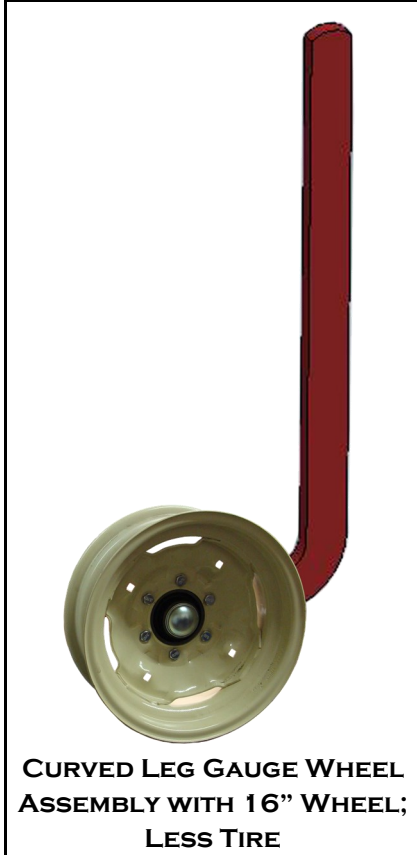

CURVED LEG GAUGE WHEEL
ASSEMBLY WITH 16" WHEEL;
LESS TIRE



YOKE STYLE PNEUMATIC

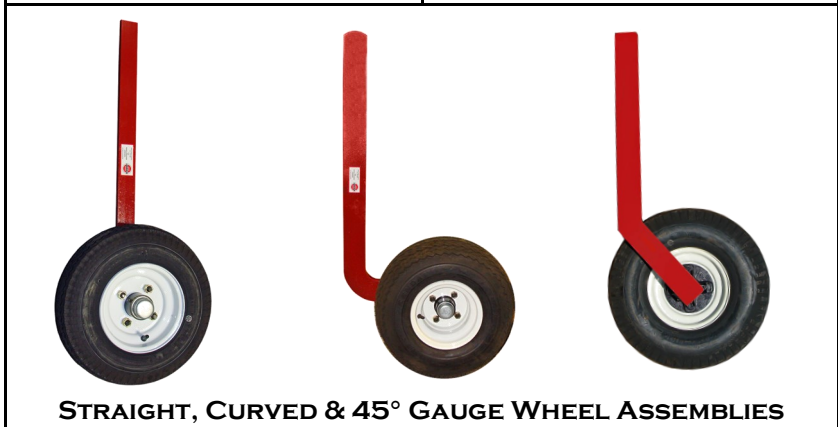

STRAIGHT, CURVED & 45° GAUGE WHEEL ASSEMBLIES

www.norwest-mfg.com

3-Point Tools 200-501

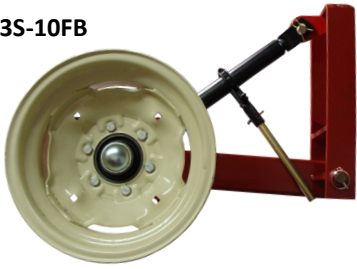

GAUGE WHEELS

ADJUSTABLE GAUGE WHEELS
MAX CAPACITY: 3560 LBS.

NORWEST PART NUMBER	DESCRIPTION	TOOL BAR SIZE		MOUNTING HARDWARE				
		VERT.	HORIZ.	U-BOLT	HEX BOLT	LOCK WASHER	NUT	STRAP/CAP
G3S-10FB G3S-11FB	Adjustable Gauge Wheel, Single Leg, Double Bracket, Adjustable Gauge Wheel, Single Leg, Single Bracket, LESS MOUNTING HARDWARE							
G3S-10FB44	Adjustable Gauge Wheel, Single Leg, Double Bracket, w/ mounting hardware for 4" x 4" tool bar.	4"	4"	FUB4060-78 (Qty. 2)	N/A	FLW58 (Qty. 4)	FHN58 (Qty. 4)	N/A
G3S-10FB77 G3S-11FB77	Adjustable Gauge Wheel, Single Leg, Double Bracket, Adjustable Gauge Wheel, Single Leg, Single Bracket, w/ mounting hardware for 7" x 7" tool bar.	7"	7"	16-03204 (Qty. 2)	N/A	FLW78 (Qty. 4)	FHN78 (Qty. 4)	N/A
G3S-10A G3S-11A	Adjustable Gauge Wheel, Single Leg, Double Bracket, Adjustable Gauge Wheel, Single Leg, Single Bracket, w/ mounting hardware for 2-1/4" Ø tool bar.	2-1/4" Ø BAR		N/A	FHB78500G5 (Qty. 4)	FLW78 (Qty. 4)	FHN78 (Qty. 4)	342SH - STRAP (2) 706 - CAP (2)

*** Mounting Hardware available for: 4" x 4", 4" x 6", 7" x 5",
 7" x 7", and 2-1/4" Ø size Tool Bars**

Norwest Part #

G3S-11FB

Less Mounting Hardware



G3S-11FB77

G3S-11A

w/Mounting Hardware

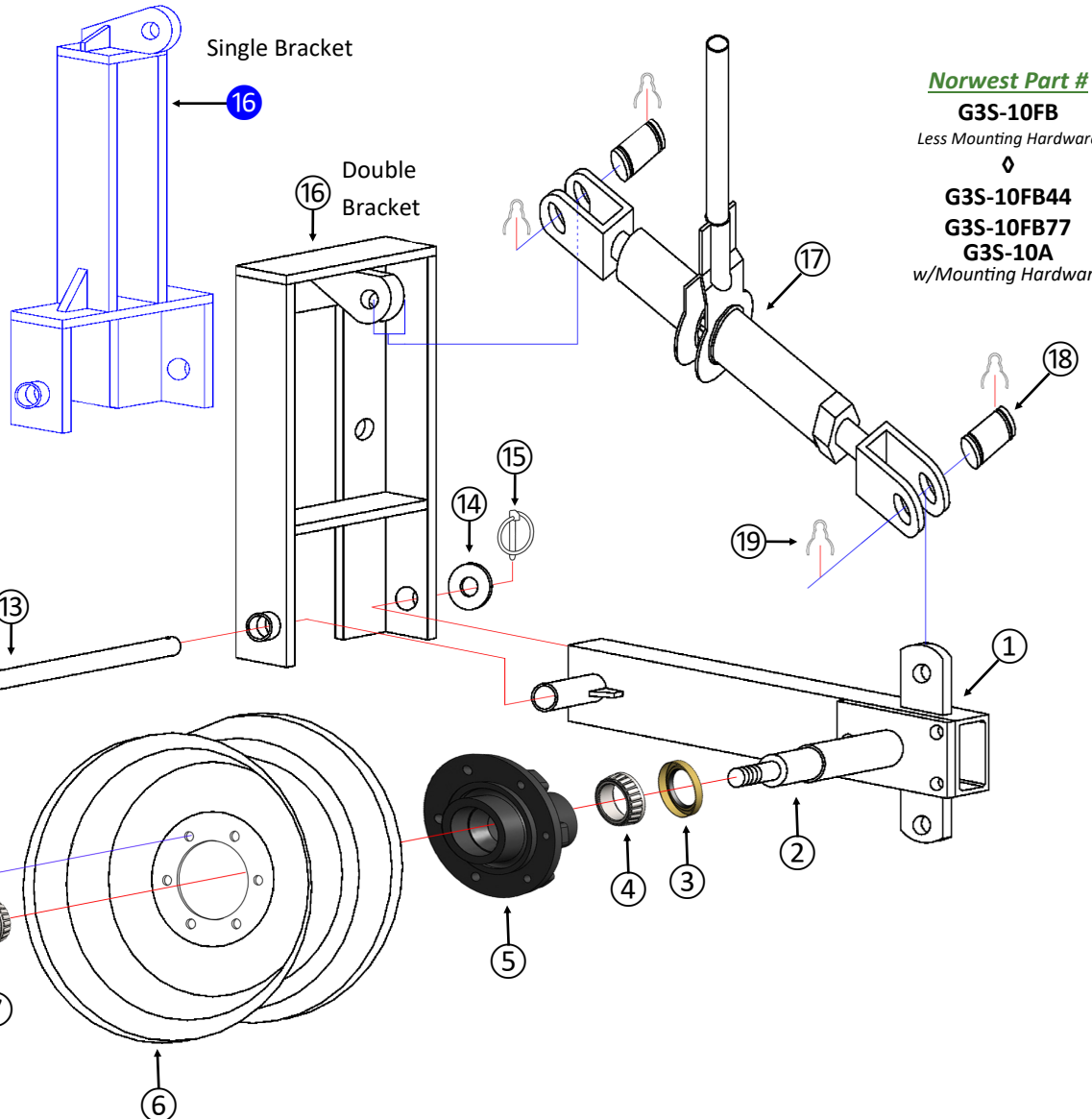

Norwest Part #

G3S-10FB

Less Mounting Hardware



G3S-10FB44

G3S-10FB77

G3S-10A

w/Mounting Hardware

Reference Number	Description	Norwest Part Number	INDUSTRY STANDARD NUMBER	Required Pcs.	Reference Number	Description	Norwest Part Number	Required Pcs.
①	G3 Leg <i>(leg is both Right & Left)</i>	G3L-100		1	⑬	1" Pivot Pin	G34P-100	1
②	1-3/4" 888 Spindle Complete*	GQ-888S	280743	1	⑭	1" Flat Washer	FFW100	1
③	Seal for 888 Hub	906284	16289	1	⑮	1/4" Lynchpin	21920	1
④	Inner Bearing for 888 Hub	910264	JL69349	1	⑯	Right or Left Hand, Single Leg; Double Bracket; Mounting Bracket	G34B-200	1
⑤	6 on 6" Bolt Center Hub Complete*	GQ-888H	280550	1	⑰	Right or Left Hand, Single Leg; Single Bracket; Mounting Bracket	G34B-200S	1
⑥	6 on 6" 16" Wheel; Fits 888 Hub	G3W-15		1	⑱	Ratchet Jack w/ Pins	22590	1
⑦	Outer Bearing for 888 Hub	910259	LM67048	1	⑲	Cylinder Pin for Ratchet Jack	10205	2
⑧	Flat Washer	913683	913683	1				
⑨	Castle Nut	912952	912952	1				
⑩	Cotter Pin	905936	905936	1				
⑪	Dust Cap for 888 Hub	909905	1604	1				
⑫	Lug Bolts for 888 Hub	943549	943549	6				

G3S-10FB BREAKDOWN ON PAGE 200-502

* See Section 200-40 for Hub & Spindle Breakdowns

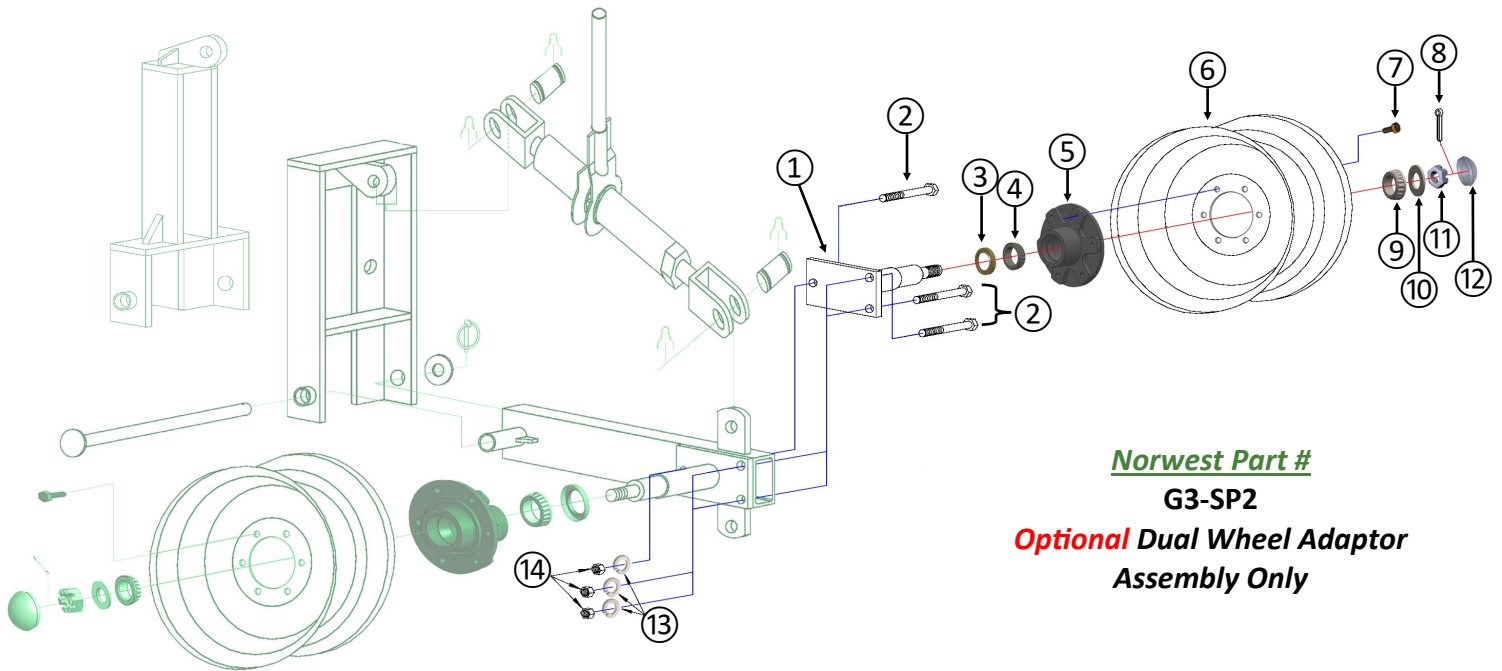

Norwest Part #
G3-SP2
Optional Dual Wheel Adaptor Assembly Only

Ref. #	Description	Norwest Part #	IND. STD. #	Req. Pcs.	Ref. #	Description	Norwest Part #	IND. STD. #	Req. Pcs.
①	Dual Wheel Adaptor Plate w/ Spindle	G3-SP1		1	⑧	Cotter Pin	905936	905936	1
②	5/8" X 4" Hex Bolt	FHB58400G5		3	⑨	Outer Bearing for 888 Hub	910259	LM67048	1
③	Seal for 888 Hub	906284	16289	1	⑩	Flat Washer	913683	913683	1
④	Inner Bearing for 888 Hub	910264	JL69349	1	⑪	Castle Nut	912952	912952	1
⑤	6 on 6" Bolt Center Hub Complete*	GQ-888H	280550	1	⑫	Dust Cap for 888 Hub	909905	1604	1
⑥	6 on 6" 16" Wheel; Fits 888 Hub	G3W-15		1	⑬	5/8" Lock Washer	FLW58		3
⑦	Lug Bolts for 888 Hub	943549	943549	6	⑭	5/8" Hex Nut	FHN58		3

* See Section 200-40 for Hub & Spindle Breakdowns



G3D-10FB

GAUGE WHEELS

ADJUSTABLE GAUGE WHEELS
MAX CAPACITY: 7120 LBS.

NORWEST PART NUMBER	DESCRIPTION	TOOL BAR SIZE		MOUNTING HARDWARE				
		VERT.	HORIZ.	U-BOLT	HEX BOLT	LOCK WASHER	NUT	STRAP/CAP
G3D-10FB G3D-11FB	Adjustable Dual Wheel Gauge Wheel, Double Bracket, Adjustable Dual Wheel Gauge Wheel, Single Bracket, LESS MOUNTING HARDWARE	* Mounting Hardware available for: 4" x 4", 4" x 6", 7" x 5", 7" x 7", and 2-1/4" ϕ size Tool Bars						

Norwest Part #

G3D-10FB
 * Less Mounting Hardware

Norwest Part #

G3D-11FB
 * Less Mounting Hardware

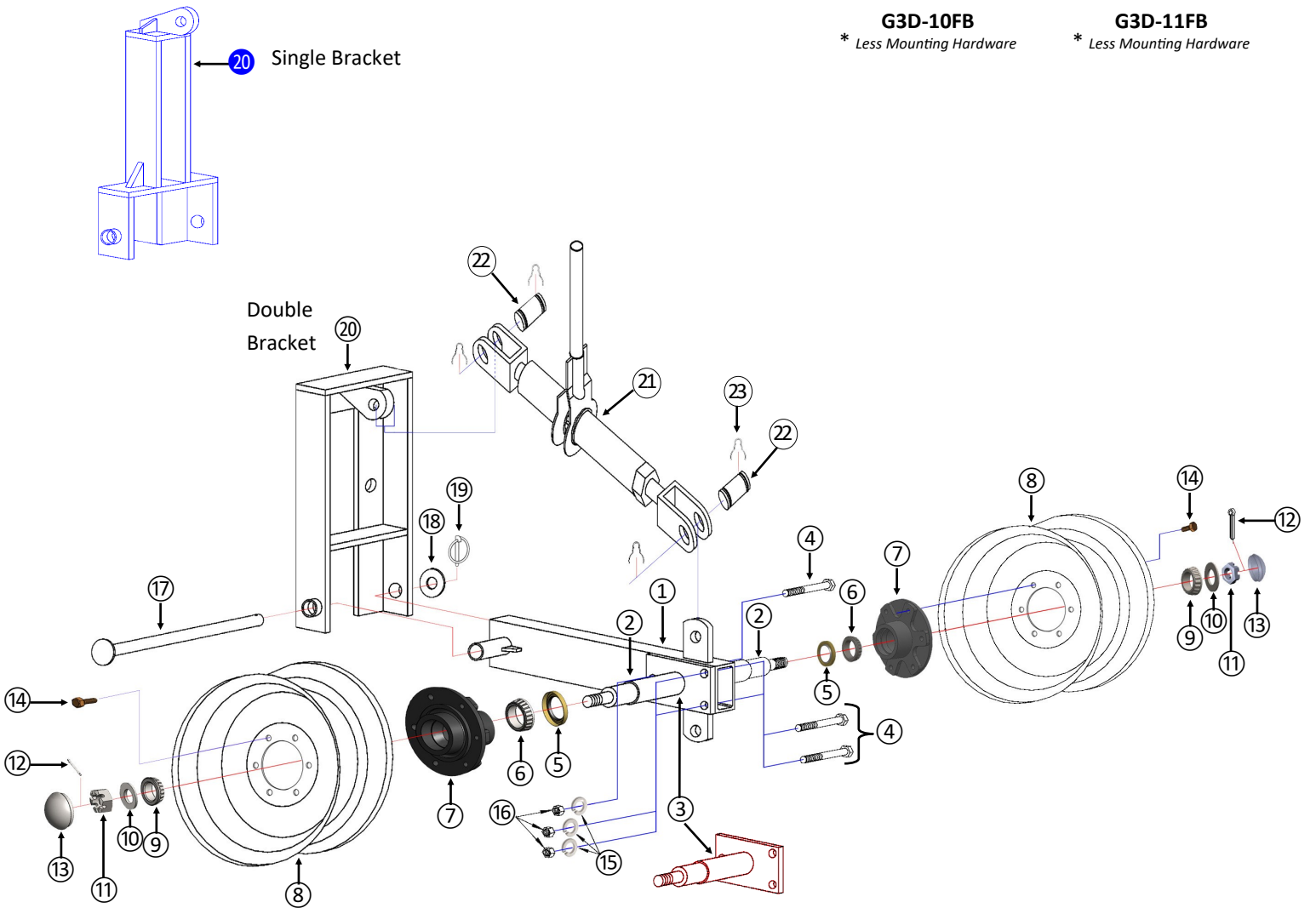

www.norwest-mfg.com

Reference Number	Description	Norwest Part Number	INDUSTRY STANDARD NUMBER	Required Pcs.
①	G3 Leg (<i>leg is both Right & Left</i>)	G3L-100		1
②	1-3/4" 888 Spindle Complete*	GQ-888S	280743	1
③	Dual Wheel Adaptor Plate w/ Spindle	G3-SP1		1
④	5/8" X 4" Hex Bolt	FHB58400G5		3
⑤	Seal for 888 Hub	906284	16289	2
⑥	Inner Bearing for 888 Hub	910264	JL69349	2
⑦	6 on 6" Bolt Center Hub Complete*	GQ-888H	280550	2
⑧	6 on 6" 16" Wheel; Fits 888 Hub	G3W-15		2
⑨	Outer Bearing for 888 Hub	910259	LM67048	2
⑩	Flat Washer	913683	913683	2
⑪	Castle Nut	912952	912952	2
⑫	Cotter Pin	905936	905936	2
⑬	Dust Cap for 888 Hub	909905	1604	2
⑭	Lug Bolts for 888 Hub	943549	943549	12
⑮	5/8" Lock Washer	FLW58		3
⑯	5/8" Hex Nut	FHN58		3
⑰	1" Pivot Pin	G34P-100		1
⑱	1" Flat Washer	FFW100		1
⑲	1/4" Lynchpin	21920		1
⑳	Right or Left Hand, Single Leg; Double Bracket; Mounting Bracket	G34B-200		1
㉑	Right or Left Hand, Single Leg; Single Bracket; Mounting Bracket	G34B-200S		1
㉒	Ratchet Jack w/ Pins	22590		1
㉓	Cylinder Pin for Ratchet Jack	10205		2
㉔	Hitch pin (Hairpin) Clip	60870		4

G3D-10FB BREAKDOWN ON PAGE 200-504

*** See Section 200-40 for Hub & Spindle Breakdowns**

Don't See What you Need?

GIVE US A CALL!



208-436-1770

3-Point Tools 200-505



YOKE STYLE GAUGE WHEELS

G4-10FB

ADJUSTABLE, YOKE STYLE GAUGE WHEELS
 MAX CAPACITY: 2100 LBS.

NORWEST PART NUMBER	DESCRIPTION	TOOL BAR SIZE		MOUNTING HARDWARE			
		VERT.	HORIZ.	U-BOLT	HEX BOLT	LOCK WASHER	NUT
G4-10FB	Adjustable, Heavy Duty, Yoke Style Gauge Wheel, LESS MOUNTING HARDWARE	* Mounting Hardware available for: 4" x 4", 4" x 6", 7" x 5", 7" x 7", and 2-1/4" Ø size Tool Bars					

Norwest Part

G4-10FB

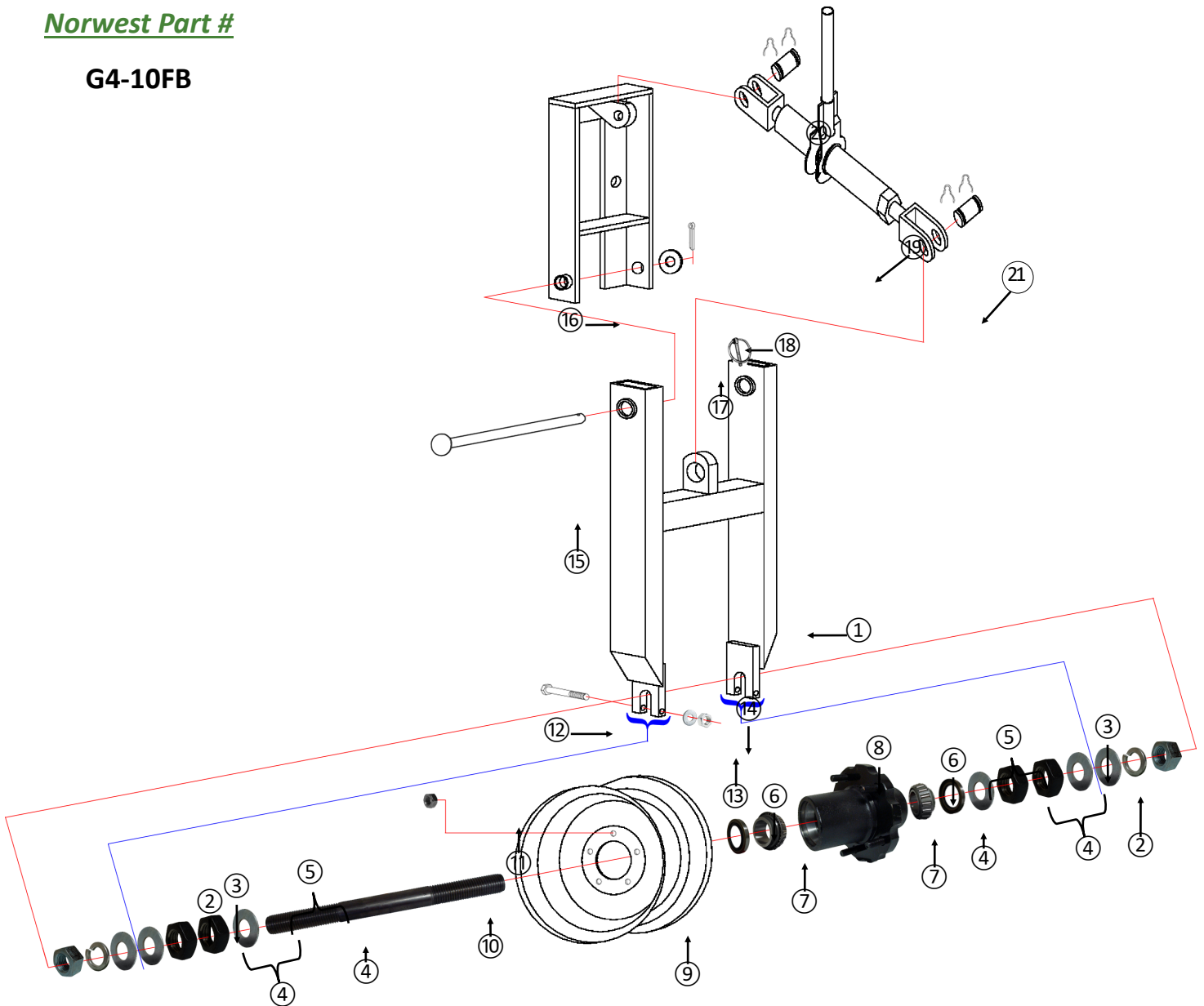

www.norwest-mfg.com

Reference Number	Description	Norwest Part Number	INDUSTRY STANDARD NUMBER	Required Pcs.
①	Double Yoke Style Leg (Leg is Both Right & Left Hand)	G4L-100		1
②	1-3/8" Hex Nut	FHN138		2
③	1-3/8" Lock Washer	FLW138		2
④	1-3/8" Flat Washer	FFW138		6
⑤	1-3/8" Jam Nut	FJN138		4
⑥	Inner/Outer Seal for G4 Hub	906295	17617	2
⑦	Inner/Outer Bearing for G4 Hub	910270	14136A	2
⑧	5 on 5" Bolt Center Hub Complete*	G4-HUB	281088	1
⑨	5 on 5" 16" Wheel; Fits G4 Hub	G4W-15		1
⑩	1-3/8" X 16-1/2" Dual Thread Spindle	G4-SP1N		1
⑪	Lug nuts for G4 Hub	912919	912919	5
⑫	1/2" x 4" Gr. 5 Hex Bolt	FHB12400G5		2
⑬	1/2" Lock Washer	FLW12		2
⑭	1/2" Hex Nut	FHN12		2
⑮	1" Pivot Pin	G4P-100		1
⑯	Right or Left Hand Bracket; Double Strap Unit	G34B-200		1
⑰	1" Flat Washer	FFW100		1
⑱	1/4" Lynchpin	21920		1
⑲	Ratchet Jack w/ Pins	22590		1
⑳	Hitch pin (Hairpin) Clip	60870		4
㉑	Cylinder Pin for Ratchet Jack	10205		2

G4-10FB BREAKDOWN ON PAGE 200-506

*** See Section 200-40 for Hub & Spindle Breakdowns**

Need Sickle Guards? Rake Teeth? Bale Spears? We can help!

Check Out Section 10 - Hay Parts

Do Your Tillage Parts need Replacing?

Check Out Section 100 - Tillage

Gauge Wheel Assemblies

Max Capacity: 1260 Lbs.

Straight Leg Gauge Wheel Assemblies

COMPLETE PART NUMBER ⑩	DESCRIPTION	LEG W/SPINDLE ONLY (Less Hub & Wheel Assembly) ① ① ①	SPINDLE PART NUMBER	HUB PART NUMBER	TIRE SPECS (Rubber Only)	WHEEL & TIRE ASSEMBLY PART # ⑪
5/8" x 2" MATERIAL						
G58-480	5/8" X 2" X 32"	G1SL-580 (R & L)	G1-SP	G1-HUB	4.80" x 8"	G1TW-480
3/4" x 2-1/2" MATERIAL						
G34-480	3/4" X 2-1/2" X 34"	G1SL-340 (R & L)	G1-SP	G1-HUB	4.80" x 8"	G1TW-480
G34-570	3/4" X 2-1/2" X 34"	G1SL-340 (R & L)	G1-SP	G1-HUB	5.70" x 8"	G1TW-570
1" x 3" MATERIAL						
G1-480H	1" X 3" X 36"	G1SL-300 (R & L)	G1-SP	G1-HUB	4.80" x 8"	G1TW-480
G1-570H	1" X 3" X 36"	G1SL-300 (R & L)	G1-SP	G1-HUB	5.70" x 8"	G1TW-570
G1-950H	1" X 3" X 36"	G1SL-300 (R & L)	G1-SP	G1-HUB	18" x 8.50" x 9"	G1TW-950

Curved Leg Gauge Wheel Assemblies

5/8" x 2" MATERIAL						
G58-480L (Left)	5/8" X 2" X 36"	G1LL-580 (Left)	G1-SP	G1-HUB	4.80" x 8"	G1TW-480
G58-480R (Right)		G1LR-580				
3/4" x 2-1/2" MATERIAL						
G34-480L (Left)	3/4" X 2-1/2" X 36"	G1LL-340 (Left)	G1-SP	G1-HUB	4.80" x 8"	G1TW-480
G34-480R (Right)		G1LR-340				
G34-570L (Left)	3/4" X 2-1/2" X 36"	G1LL-340 (Left)	G1-SP	G1-HUB	5.70" x 8"	G1TW-570
G34-570R (Right)		G1LR-340				
1" x 3" MATERIAL						
G1-480HL (Left)	1" X 3" X 36"	G1LL-300 (Left)	G1-SP	G1-HUB	4.80" x 8"	G1TW-480
G1-480HR (Right)		G1LR-300				
G1-570HL (Left)	1" X 3" X 36"	G1LL-300 (Left)	G1-SP	G1-HUB	5.70" x 8"	G1TW-570
G1-570HR (Right)		G1LR-300				
G1-950HL (Left)	1" X 3" X 36"	G1LL-300 (Left)	G1-SP	G1-HUB	18" x 8.50" x 9"	G1TW-950
G1-950HR (Right)		G1LR-300				

45° Angle Leg Gauge Wheel Assemblies

5/8" x 2" MATERIAL						
G58X-480L (Left)	5/8" X 2" X 32"	G1XL-580 (Left)	G1-SP	G1-HUB	4.80" x 8"	G1TW-480
G58X-480R (Right)		G1XR-580				
3/4" x 2-1/2" MATERIAL						
G34X-480L (Left)	3/4" X 2-1/2" X 34"	G1XL-340 (Left)	G1-SP	G1-HUB	4.80" x 8"	G1TW-480
G34X-480R (Right)		G1XR-340				
G34X-570L (Left)	3/4" X 2-1/2" X 34"	G1XL-340 (Left)	G1-SP	G1-HUB	5.70" x 8"	G1TW-570
G34X-570R (Right)		G1XR-340				

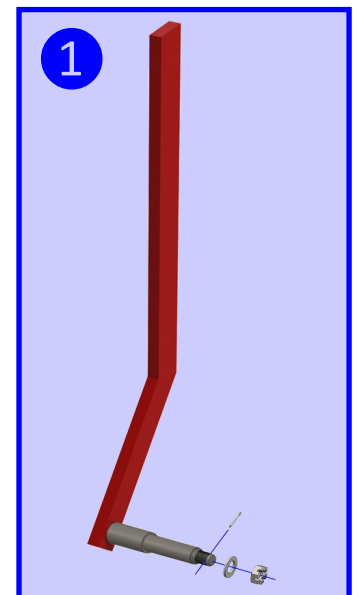
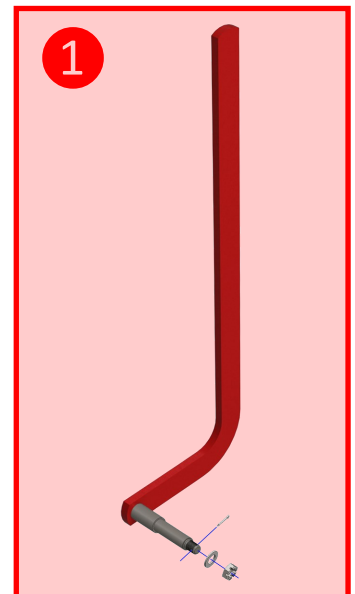
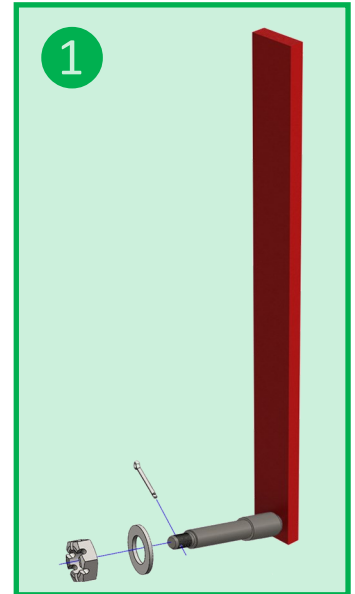

Gauge Wheel Component Parts List

REF. #	DESCRIPTION	PART NUMBER	Industry Standard #	REQ. PCS.
①	1. 5/8" x 2" x 32" • Straight Leg • (Either Right or Left Hand) 2. 3/4" x 2-1/2" x 34" • Straight Leg • (Either Right or Left Hand) 3. 1" x 3" x 36" • Straight Leg • (Either Right or Left Hand)	1. G1SL-580 2. G1SL-340 3. G1SL-300		1
①	1. 5/8" x 2" x 36" • Curved Leg • (Left Hand/Right Hand) 2. 3/4" x 2-1/2" x 36" • Curved Leg • (Left Hand/Right Hand) 3. 1" x 3" x 36" • Curved Leg • (Left Hand/Right Hand)	1. G1LL-580 / G1LR-580 2. G1LL-340 / G1LR-340 3. G1LL-300 / G1LR-300		1
①	1. 5/8" x 2" x 32" • 45° Angle Leg • (Left Hand/Right Hand) 2. 3/4" x 2-1/2" x 34" • 45° Angle Leg • (Left Hand/Right Hand)	1. G1XL-580 / G1XR-580 2. G1XL-340 / G1XR-340		1
②	Spindle Complete	G1-SP	280799	1
③	Seal	906282	12437	1
④	Inner / Outer Bearing	910254	144643	2
⑤	Hub Complete*	G1-HUB	280306	1
⑥	Lug Nut	912918	912918	4
⑦	Flat Washer	913608	913608	1
⑧	Castle Nut	912953	912953	1
⑨	Cotter Pin	905936	905936	1
⑩	Dust Cap	909900	909900	1
⑪	15" Wheel & Tire (fits G1 Hub)	G1TW-480 G1TW-570 G1TW-950		1

* See Section 200-40 for Hub & Spindle Breakdowns

Complete part numbers come with leg, spindle, complete hub, wheel & tire, and other associated parts (above).
Legs are made from heavy duty plow steel. ♦ Please order clamps separately. ♦

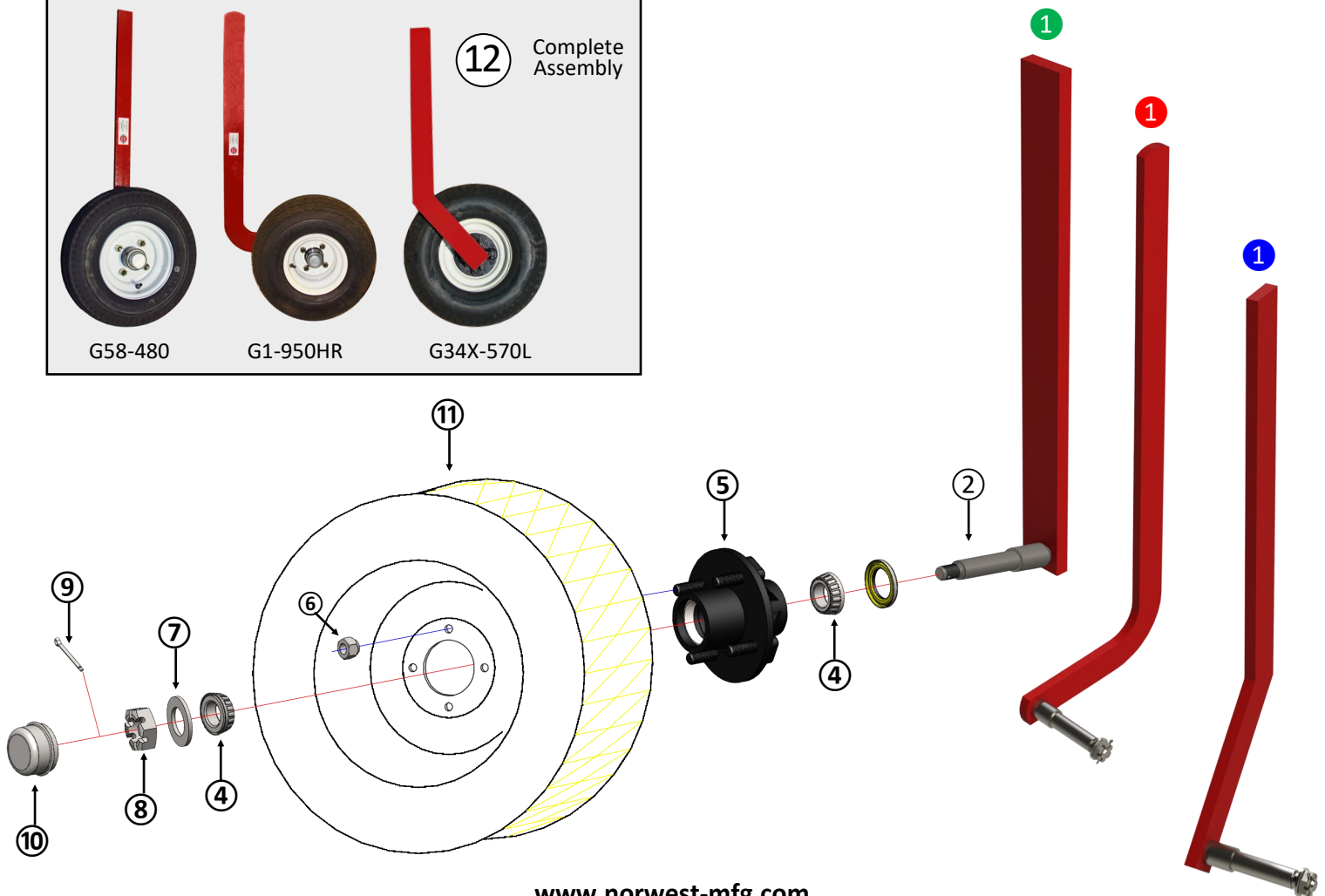





www.norwest-mfg.com



GAUGE WHEELS

ZERO PRESSURE GAUGE WHEEL LOAD RATING: 350 LBS. MAX at 5 MPH MAX

	Norwest Part Number ← 116012L Description Zero Pressure Gauge Wheel Assembly: Left Hand Weight (LBS.) 30.50		Norwest Part Number ← 116012R Description Zero Pressure Gauge Wheel Assembly: Right Hand Weight (LBS.) 30.50		Norwest Part Number ← 116017 Description Tire & Wheel Assembly w/ Bearing Weight (LBS.) 10.00		Norwest Part Number ← FH206-18G/2 Description 206 Series Bearing; 1-1/8" Round Boar; Relubricable, with Eccentric Locking Collar Weight (LBS.) 1.0
--	---	---	--	---	---	---	--

Norwest Part #

116012L

Zero Pressure Gauge Wheel Assembly: Left

116012R

Zero Pressure Gauge Wheel Assembly: Right

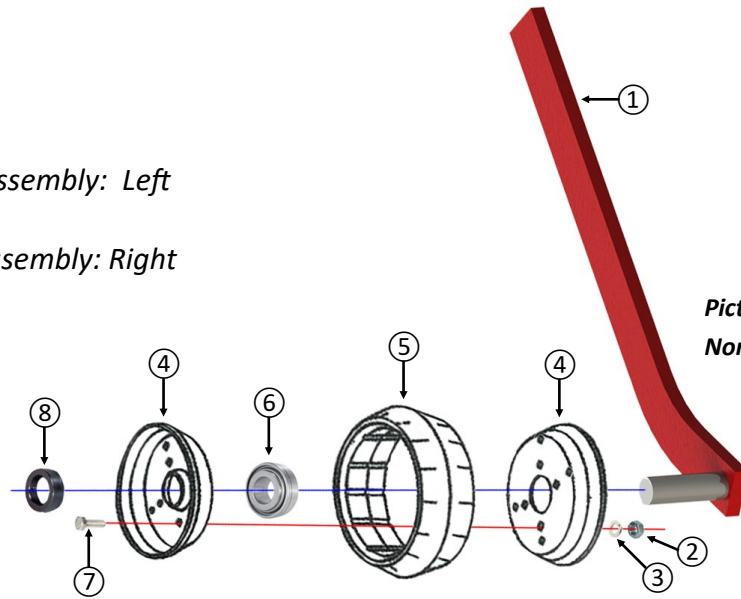



Pictured is a breakdown of Norwest Part # 116012R

ZERO PRESSURE GAUGE WHEEL

Reference Number	Description	Norwest Part Number	Required Pcs.
①	5/8" x 2" Spring Steel Shank w/ Axle: Left Hand	116104	1
	5/8" x 2" Spring Steel Shank w/ Axle: Right Hand	116013	
②	3/8" Hex Nut	FHN38	8
③	3/8" Lock Washer	FLW38	8
④	Wheel Half for Zero Pressure Gauge Wheel: 1/2 Wheel Only	116019	2
⑤	Semi-Pneumatic 4" x 12" Zero Pressure Tire	16-35009	1
⑥	206 Series Bearing; 1-1/8" Round Boar; Relubricable	FH206-18G/2	1
⑦	3/8" x 3/4" Hex Bolt	FHB3875G5	8
⑧	Eccentric Locking Collar for FH206-18G/2 <i>(Sold as part of Bearing Assembly: Not Sold Separately)</i>	N/A	1

YOKE STYLE PNEUMATIC GAUGE WHEEL

CARRYING CAPACITY: 795 LBS. • HEIGHT: 31" • VERTICAL ADJUSTMENT: 14"

	Norwest Part Number		Norwest Part Number
	← 116165		← 116170
	Description		Description
	8" Yoke Style Gauge Wheel Assembly		Tire & Wheel Assembly w/ Greasable Roller Bearings: 16-1/2" x 6-1/2" x 8" (6 Ply) Tire on 8" Rim
Weight (LBS.)	51.00	Weight (LBS.)	14.00

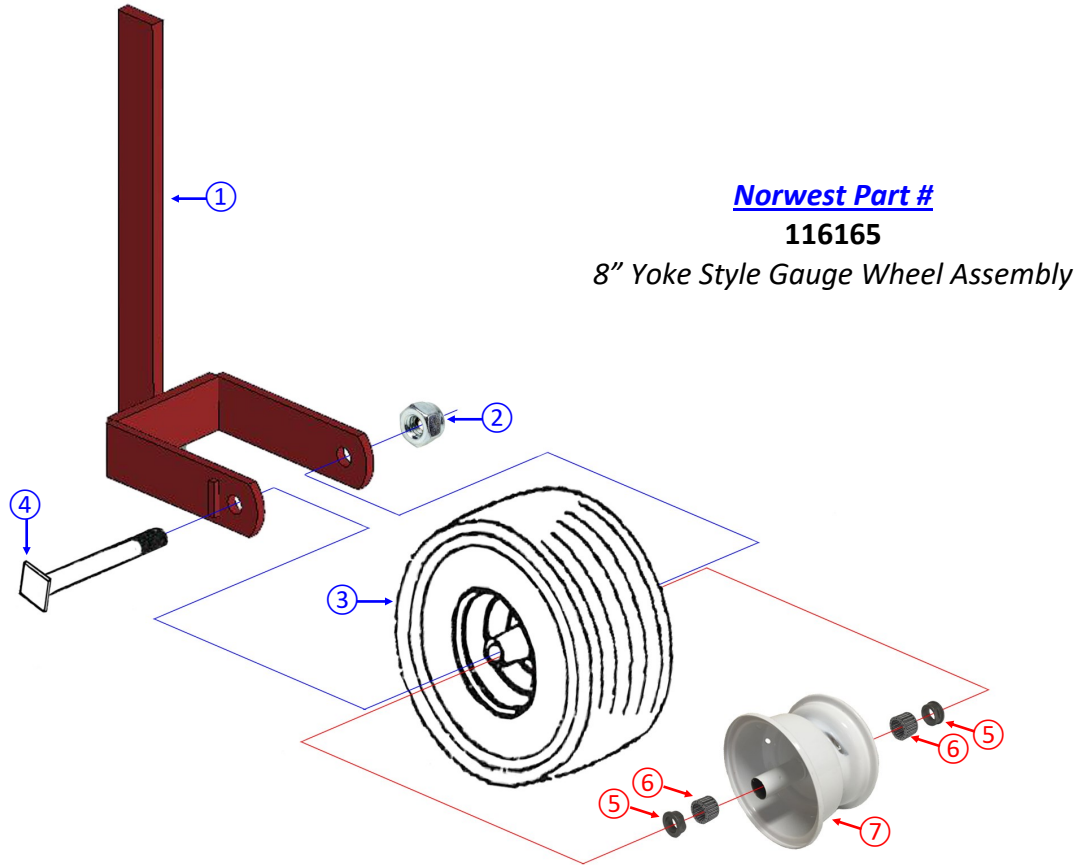

YOKE STYLE PNEUMATIC GAUGE WHEEL

Reference Number	Description	Norwest Part Number	Required Pcs.
①	3/4" x 2-1/2" Spring Steel Yoke Leg; Complete	116322	1
②	1" Nylok Hex Nut	FYHN100	1
③	Tire & Wheel Assembly; Complete	116170	1
④	1" x 9-1/2" Spindle	116168	
116170: Tire & Wheel Assembly Replacement Parts			
⑤	Flanged Bushing: 1.01" I.D. - 1.37" O.D.	116178	2
⑥	1" x 1-3/8" Roller Bearing	116174	2
⑦	8" Wheel Only <i>Tire Not Included</i>	116172	1

CURVED LEG GAUGE WHEEL ASSEMBLY WITH 16" WHEEL, LESS TIRE
LOAD RATING: 35600 LBS. MAX

NORWEST PART NUMBER

DESCRIPTION

G1-545L

Gauge Wheel Assembly with 1" x 3" Curved Leg, Less Tire *(Left Hand)*

G1-545R

Gauge Wheel Assembly with 1" x 3" Curved Leg, Less Tire *(Right Hand)*

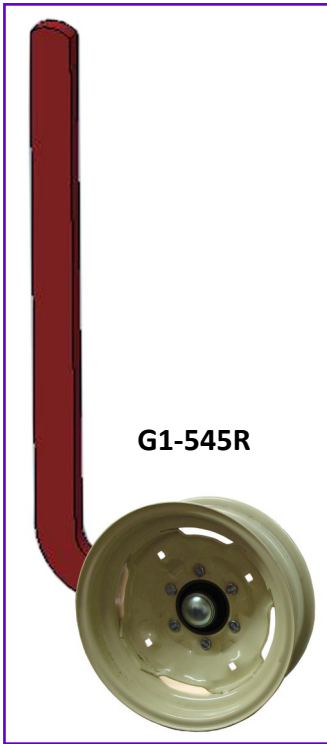

G1-545R

Norwest Part #

G1-545L
G1-545R

Curved Leg Gauge Wheel

① →

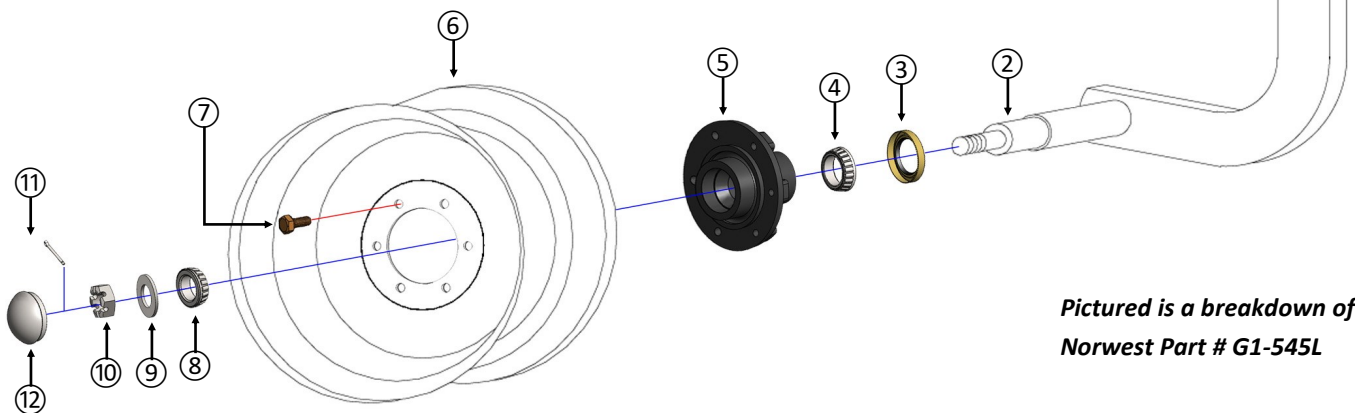

*Pictured is a breakdown of
Norwest Part # G1-545L*

Curved Leg Gauge Wheel Assembly with 16" Wheel; Less Tire

REF. #	DESCRIPTION	PART NUMBER	Industry Standard #	REQ. PCS.	REF. #	DESCRIPTION	PART NUMBER	Industry Standard #	REQ. PCS.
①	1" x 3" Curved Gauge Wheel Leg (Left)	GRCLL-100		1	⑦	Lug Bolts for 888 Hub	943549	943549	6
	1" x 3" Curved Gauge Wheel Leg (Right)	GRCLR-100			⑧	Outer Bearing for 888 Hub	910259	LM67048	1
②	1-3/4" 888 Spindle Complete*	GQ-888S	280743	1	⑨	Flat Washer	913683	913683	1
③	Seal for 888 Hub	906284	16289	1	⑩	Castle Nut	912952	912952	1
④	Inner Bearing for 888 Hub	910264	JL69349	1	⑪	Cotter Pin	905936	905936	1
⑤	6 on 6" Bolt Center Hub Complete*	GQ-888H	280550	1	⑫	Dust Cap for 888 Hub	909905	1604	1
⑥	6 on 6" 16" Wheel; Fits 888 Hub	G3W-15							

* See Section 200-40 for Hub & Spindle Breakdowns

*Complete part numbers come with leg, spindle, hub and other associated parts (above).
Legs are made from heavy duty plow steel.*

Please order clamps separately.

www.norwest-mfg.com

Solid V-Rubber Guide Wheel Assemblies



NORWEST PART #
VG1-420R

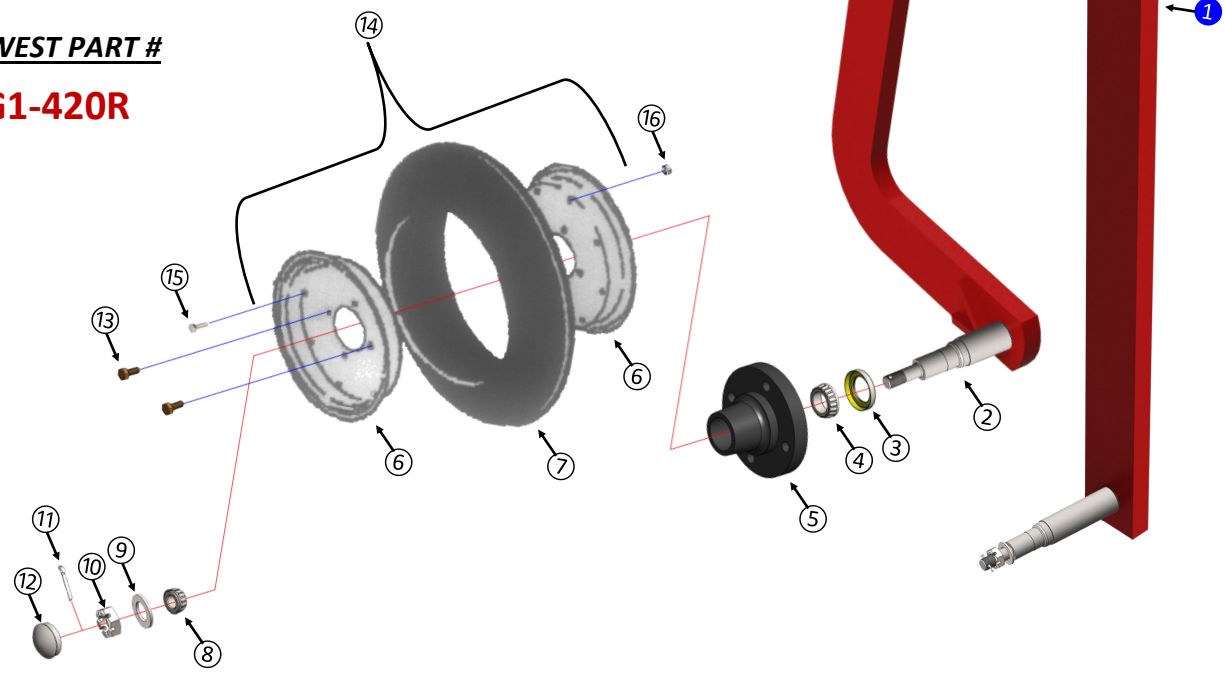

Reference Number	Description	Norwest Part Number	Industry Standard Number	Required Pcs.
①	3/4" x 2-1/2" x 36" Curved Guide Wheel Leg: <i>Left Hand</i>	G633LL-340		1
	3/4" x 2-1/2" x 36" Curved Guide Wheel Leg: <i>Right Hand</i>	G633LR-340		
①	1" x 3" x 36" Curved Guide Wheel Leg: <i>Left Hand</i>	G633LL-300		1
	1" x 3" x 36" Curved Guide Wheel Leg: <i>Right Hand</i>	G633LR-300		
①	1" x 3" x 36" Straight Guide Wheel Leg: <i>Left or Right Hand</i>	G633SL-300		1
②	Spindle Complete*	GQ-633S	280741	1
③	Seal	906296	14975	1
④	Inner Bearing	910259	LM67048	1
⑤	Hub Complete*	GQ-633H	280500	1
⑥	4" x 16" x 11" Rim Half for Bolt on Hub (1/2 Rim Only)	VW420-75		2
⑦	4" x 20" Solid V-Rubber Tire (Tire Only)	VT420		1
⑧	Outer Bearing	910260	LM11949	1
⑨	Flat Washer	913608	913608	1
⑩	Castle Nut	912954	912954	1
⑪	Cotter Pin	905936	905936	1
⑫	Dust Cap	909911A	1527	1
⑬	Lug Bolt	943549	943549	4
⑭	4" x 20" V-Tread Tire & Wheel (Complete Assembly)	VA420-75		1
⑮	5/16" x 5/8" Hex Bolt for Rim Assembly	FHB5658G5		8
⑯	5/16" Hex Crimp Lock Nut for Rim Assembly	FHLN56		8

* See Section 200-322 for V-Tire Options